



SPECIFICATION SHEET

SPECIFICATION SHEET NO.	N0909- UZ476M035HEHTA
DATE	Sept. 09, 2021
REVISION	A0
DESCRIPTION	<p>SMD Aluminum Electrolytic Capacitors, Extra Low ESR type</p> <p>UZ series, 2 pads Capacitance: 47μF, Tolerance ±20%, Voltage 35V, Case size: Ø6.3*L5.4mm, Impedance 0.36Ω, Ripple Current 240 mA Max.</p> <p>2000 Hours, Operating Temp. Range -55°C ~+105°C</p> <p>RoHS/RoHS III Compliant & Halogen Free</p> <p>Package in Tape/Reel, 1000pcs/Reel</p>
CUSTOMER	
CUSTOMER PART NUMBER	
CROSS REF. PART NUMBER	
ORIGINAL PART NUMBER	Aillen CAE476M1VHUZEE4TR
PART CODE	UZ476M035HEHTA

VENDOR APPROVE			
Issued/Checked/Approved			
DATE: Sept. 09, 2021			

CUSTOMER APPROVE	
DATE:	

SMD ALUMINUM ELECTROLYTIC CAPACITORS UZ SERIES

MAIN FEATURE

- SMD Aluminum Electrolytic Capacitors
- Designed for SMD on PCB
- Applicable to automatic mounting machine
- RoHS Compliant and Halogen Free



APPLICATION

- High-density Patch Assembly Electronic Circuit, Power Supply, Lighting, Etc.

PART CODE GUIDE

RFQ

[Request For Quotation](#)

UZ	476	M	035	H	E	H	T	A
1	2	3	4	5	6	7	8	9

1) **UZ**: SMD Aluminum Electrolytic Capacitors, Extra Low ESR type, UZ series, 2 pads

2) **476**: Rated Capacitance Code, 476: 47µF

3) **M**: Capacitance tolerance code, M: ±20%; K: ±10%; V: -10% ~ ±20%,

4) **035**: Rated Voltage Code, 6R3: 6.3V; 010: 10V; 016:16V; 025: 25V; 035: 35V; 050: 50V

5) **H**: Environmental Requirements code, R: RoHS Compliant; H: RoHS III Complaint & Halogen Free

6) **E**: Aluminum Case size code, C: Ø4.0mm; D: Ø5.0mm; E: Ø6.3mm; F: Ø8.0mm; G: Ø10.0mm

7) **H**: Aluminum case Heigh code, H: L5.4mm; J: L7.7mm; K: L10.2mm; L: L11.5mm; M: L12.5mm; N: L13.5mm

8) **T**: Package in Tape/Reel, 500pcs/Reel

9) **A**: Internal control or Customer’s Special Code (A~Z or 1~9)

SMD ALUMINUM ELECTROLYTIC CAPACITORS UZ SERIES

Image for reference



UZ Series
Case $\phi 6.3 \times L 5.4 \text{ mm}$

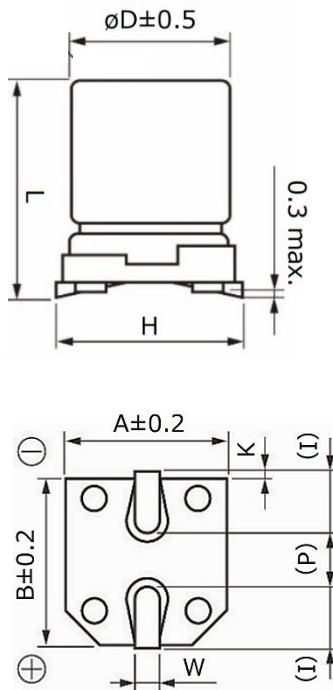

Symbol	Dimension (mm)
A	6.6
B	6.6
D	$\phi 6.3$
H	7.8 Max
I	2.6 Ref.
L	5.4 ± 0.3
K	0.50 Max.
p	1.8 Ref.
W	0.65 ± 0.1

Marking

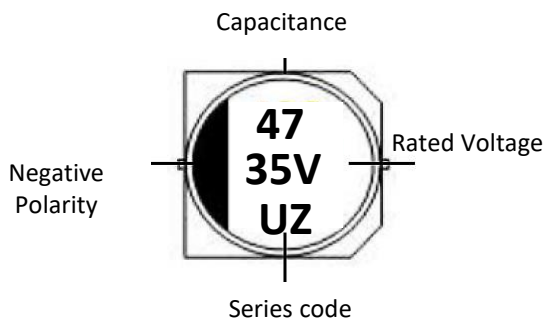

Recommended Land (mm)

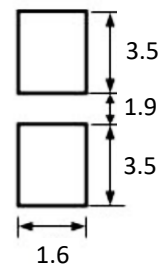

SMD ALUMINUM ELECTROLYTIC CAPACITORS UZ SERIES

CONSTRUCTION

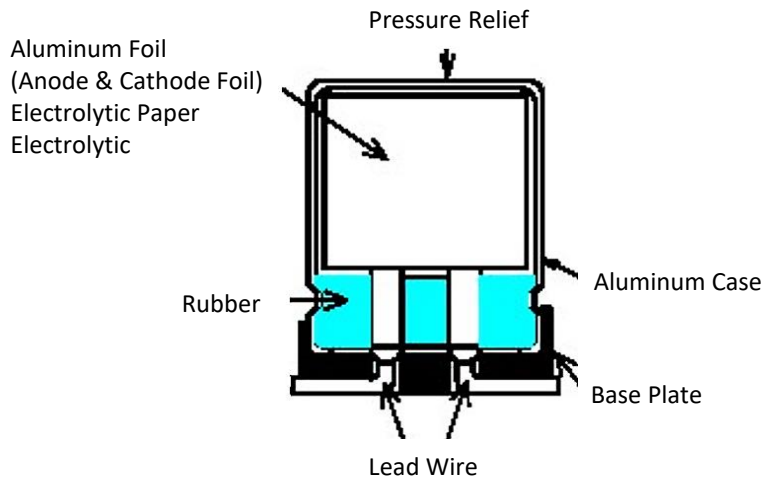

CHARACTERISTICS

Standard atmospheric conditions

The standard range of atmospheric conditions for making measurements/test as follows:

Ambient temperature: 15° C to 35° C ; Relative humidity: 45% to 85% ; Air Pressure: 86kPa to 106kPa

If there is any doubt about the results, measurement shall be made within the following conditions:

Ambient temperature: 20° C ± 2° C ; Relative humidity: 60% to 70% ; Air Pressure: 86kPa to 106kPa

As to the detailed information, please refer to following Table

Item	Characteristics
Operating Temperature Range	-55~+105°C
Rated Voltage Range	35 V
Capacitance Range	47 μF
Capacitance Tolerance at 20°C,120Hz	± 20%
Leakage Current at 20°C	$I \leq 0.01 CV (\mu A) \text{ or } 3 (\mu A)$, Whichever is greater after 2 minutes I: Leakage Current(μA) C: Rated Capacitance(μF) V: Working Voltage(V)

SMD ALUMINUM ELECTROLYTIC CAPACITORS UZ SERIES

Item	Characteristics																							
Dissipation Factor at 20°C,120Hz	<table border="1" data-bbox="479 426 1308 536"> <tr> <td>WV</td> <td>6.3</td> <td>10</td> <td>16</td> <td>25</td> <td>35</td> <td>50</td> </tr> <tr> <td>Tanδ</td> <td>0.26</td> <td>0.19</td> <td>0.16</td> <td>0.14</td> <td>0.12</td> <td>0.12</td> </tr> </table>						WV	6.3	10	16	25	35	50	Tanδ	0.26	0.19	0.16	0.14	0.12	0.12				
WV	6.3	10	16	25	35	50																		
Tanδ	0.26	0.19	0.16	0.14	0.12	0.12																		
Low Temperature Stability	<p>Impedance ratio (120 Hz)</p> <table border="1" data-bbox="458 689 1333 948"> <tr> <td>Rated Voltage (V)</td> <td>6.3</td> <td>10</td> <td>16</td> <td>25</td> <td>35</td> </tr> <tr> <td>Z-25°C/Z+20°C (120Hz)</td> <td>4</td> <td>3</td> <td>2</td> <td>2</td> <td>2</td> </tr> <tr> <td>Z-55°C/Z+20°C (120Hz)</td> <td>8</td> <td>5</td> <td>4</td> <td>3</td> <td>3</td> </tr> </table>						Rated Voltage (V)	6.3	10	16	25	35	Z-25°C/Z+20°C (120Hz)	4	3	2	2	2	Z-55°C/Z+20°C (120Hz)	8	5	4	3	3
Rated Voltage (V)	6.3	10	16	25	35																			
Z-25°C/Z+20°C (120Hz)	4	3	2	2	2																			
Z-55°C/Z+20°C (120Hz)	8	5	4	3	3																			
Load Life	<p>After applying rated voltage with max ripple current for 2000 hrs at +105°C, and then resumed 16 hours, the capacitors Shall meet the following requirements.</p> <table border="1" data-bbox="444 1176 1352 1394"> <tr> <td>Capacitance Change</td> <td colspan="5">Within ± 30% of initial value</td> </tr> <tr> <td>Dissipation Factor</td> <td colspan="5">Not more than 300% of the specified value</td> </tr> <tr> <td>Leakage Current</td> <td colspan="5">Not more than the specified value</td> </tr> </table>						Capacitance Change	Within ± 30% of initial value					Dissipation Factor	Not more than 300% of the specified value					Leakage Current	Not more than the specified value				
Capacitance Change	Within ± 30% of initial value																							
Dissipation Factor	Not more than 300% of the specified value																							
Leakage Current	Not more than the specified value																							
Shelf Life	<p>After storage for 1000hrs at +105°C, then resumed 16 hours, the capacitors Shall meet the following requirements</p> <table border="1" data-bbox="444 1549 1352 1796"> <tr> <td>Capacitance Change</td> <td colspan="5">Within ± 30% of initial value</td> </tr> <tr> <td>Dissipation Factor</td> <td colspan="5">Not more than 300% of the specified value</td> </tr> <tr> <td>Leakage Current</td> <td colspan="5">Not more than 300% of the specified value</td> </tr> </table>						Capacitance Change	Within ± 30% of initial value					Dissipation Factor	Not more than 300% of the specified value					Leakage Current	Not more than 300% of the specified value				
Capacitance Change	Within ± 30% of initial value																							
Dissipation Factor	Not more than 300% of the specified value																							
Leakage Current	Not more than 300% of the specified value																							

SMD ALUMINUM ELECTROLYTIC CAPACITORS UZ SERIES

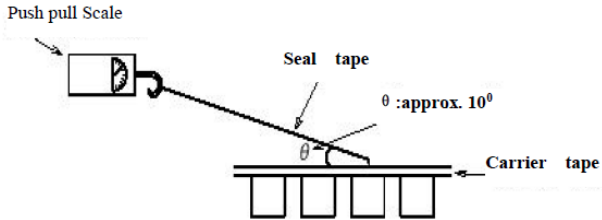
Item	Characteristics	
Resistance to Soldering Heat	The capacitors shall be kept on then hot plate maintained at 250°C for 30 seconds. After removing from the hot plate and restored at room temperature, they meet the following requirement:	
	Capacitance Change	Within $\pm 10\%$ of the initial value
	Dissipation Factor	Not more than the specified value
	Leakage Current	Not more than the specified value
Adhesion test	<p>Reasonable pulling strength: 0.1~0.7N; Pulling speed: 300mm/min</p> 	

SMD ALUMINUM ELECTROLYTIC CAPACITORS UZ SERIES

CASE SIZE & MAX RIPPLE CURRENT

Rated Voltage (V)	Capacitance (+/-20%) μ F	Case Size \varnothing *L mm	Tan δ @+105°C, 100KHz	Ripple Current mA r.m.s. @+105°C, 100KHz	Impedance Ω @20°C,100KHz
35	47	6.3*5.4	0.12	240	0.36

FREQUENCY COEFFICIENT OF ALLOWABLE RIPPLE CURRENT

Frequency	50Hz	120Hz	300Hz	1KHz	\geq 10kHz
Coefficient	0.64	0.64	0.64	0.83	1.00

WELDING METHODS AND APPLICABILITY

Welding Method	Reflow Soldering	Soldering Iron	Wave Soldering
The feasibility of	OK	OK	N/A

Conditions for the use of lead-free reflow soldering.:

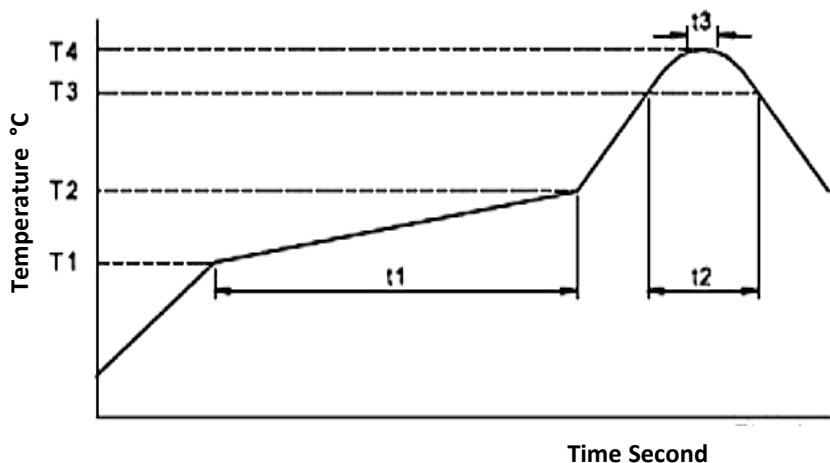

METHODS THE FOLLOWING :

Reflow soldering: please follow the temperature condition during welding. If high temperature is used, please measure and inform the capacitor temperature and reflow soldering condition. The product size is larger and its rising temperature is slower. It is not necessary to adjust the temperature of the reflow solder in accordance with the size of the product. For example, the products of 4 and 10 will be installed in the PCB over tin furnace.

SMD ALUMINUM ELECTROLYTIC CAPACITORS UZ SERIES

Precautions for soldering tin:

Related factors of reflow soldering temperature:

Product size: The product size is larger and its temperature rises slowly.

Product installation position: The temperature of PCB center is lower than that of PCB.

Reflow soldering

If possible, avoid reflow soldering twice.

If repeated reflux is unavoidable, measure and inform the first and second reflux temperature, and the time of reflow soldering.

Please do not 3 times of reflow soldering

Please follow the following conditions when soldering tin soldering:

Soldering iron maximum temperature: $350 \pm 5^{\circ}\text{C}$

Welding time: $3+1/-0$ sec

TEST METHOD AND PEAK TEMPERATURE PERMISSIBLE RANGE

Part Code		UZ476M035HEHTA
Rated Voltage (V)		35 V
Case Size		$\varnothing 6.3 * L5.4\text{mm}$
Preheating	Temperature Range (T1~T2)	$150 \sim 180^{\circ}\text{C}$
	Time (t1) Max.	100 Second
The Duration Of The	Temperature Range (T3)	230°C
	Time (t2) Max.	60 Second
The Highest Temperature	Temperature Range (T4)	260°C
	Time (t3) Max.	5 Second
Return The Number		2 times Max.

Note

- 1) Please contact us if the condition of use are higher than the
- 2) When performing 2nd reflow Soldering, please make sure the temperature of capacitor have cooled to : $5 \sim 35^{\circ}\text{C}$

SMD ALUMINUM ELECTROLYTIC CAPACITORS UZ SERIES

TAPE (Unit: mm), 1000pcs/Reel

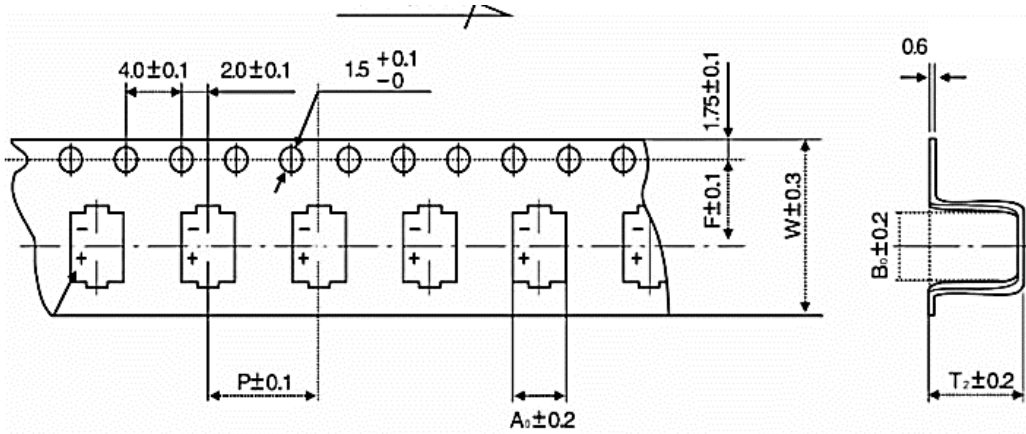

REEL (Unit: mm)

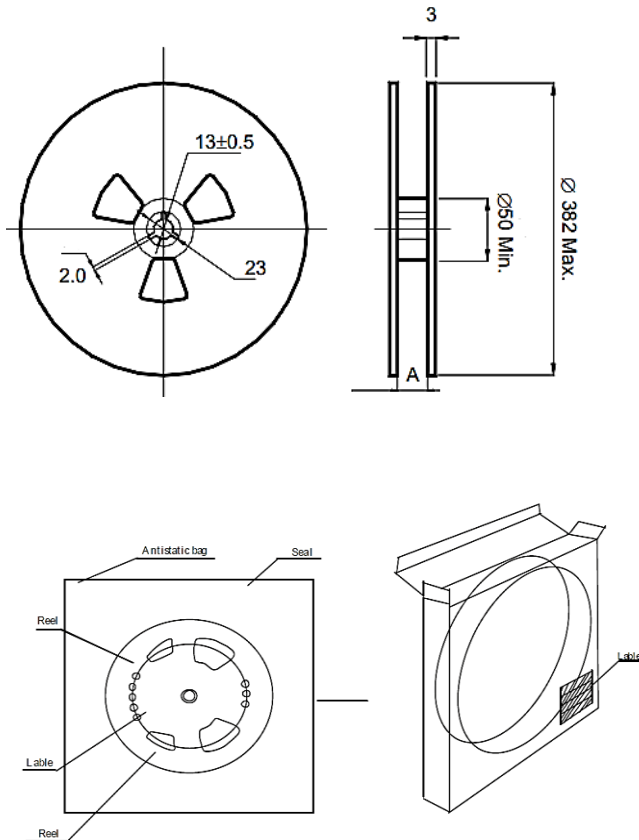

Case size: Ø6.3*L5.4mm

Symbol	Dimension (mm)
W	16.0
P	12.0
F	7.5
A 0	7.0
B 0	7.0
T 2	5.8
A	18.0+/-0.3

SMD ALUMINUM ELECTROLYTIC CAPACITORS UZ SERIES

ATTENTION FOR OP-CAP SOLDERING

Reflow soldering will reduce the rated electrostatic capacity of the product, and it should be confirmed whether reflow soldering condition meets the specification of recommended reflow soldering.

Although the actual reflow condition change is still based on the reflow soldering method, please note that the highest temperature and the electrode terminal at the bottom of the aluminum shell must not exceed the maximum temperature.

Please note: OP - CAP products during the process of reflow heating temperature should increase to more than 200 °C. If the reflow condition temperature or duration is greater than the above table, the OP-CAP product will be damaged. The electrostatic capacity of the product is reduced by about 50%, the leakage current is large (up to mA), and the outside of the capacitor is damaged.

APPLICATION GUIDELINE

Circuit Design:

- 1) Please make sure the environmental and mounting conditions to which the capacitor will be exposed are within the conditions specified in catalogue.
- 2) Operating temperature and applied ripple shall be within specification.
- 3) Appropriate capacitors which comply with the life requirement of the products should be selected when designing the circuit.
- 4) Aluminum electrolytic capacitors are polar. Make sure that no reverse voltage or AC voltage is applied to the capacitors. Please use bi-polar capacitors for a circuit that can possibly see reversed polarity.

Note: Even bi-polar capacitors cannot be used for AC voltage application.

- 5) Do not use aluminum electrolytic capacitors in a circuit that requires rapid and very frequent charge/discharge. In this type of circuit, it is necessary to use a special design capacitor with extended life characteristics.

- 6) Do not apply excess voltage.

(1) Please pay attention to that the peak voltage, which is DC voltage overlapped by ripple current, will not exceed the rated voltage.

(2) In the case where more than 2 aluminum electrolytic capacitors are used in series, please make sure that applied voltage will be lower than rated voltage and the voltage will be applied to each capacitor equally by using a balancing resistor in parallel with the capacitor.

- 7) Aluminum electrolytic capacitors shall not be used under the following environmental conditions:

(1) (a) Capacitors will be exposed to water (including condensation), brine or oil. (b) Ambient conditions that include toxic gases such as hydrogen sulfide, sulfurous acid, nitrous acid, chlorine, bromine, methyl bromide, ammonium, etc. (c) Ambient conditions that expose the capacitor to ozone, ultraviolet ray and radiation.

SMD ALUMINUM ELECTROLYTIC CAPACITORS UZ SERIES

(2) Severe vibration and physical shock conditions that exceed specification.

Vibration test condition: 10-55-10Hz

vibration frequency range : 10~55~10Hz

sweep rate : 10~55~10Hz/minute

sweep method : logarithmic

amplitude or acceleration : 1.5mm (max. acceleration is 10G)

direction of vibration : X, Y, Z direction

testing time: 2 hours per each direction

Shock is not applicable normally.

If a particular condition is required, please contact our sales office.

8) The main chemical solution of the electrolyte and the separator paper used in the capacitors are combustible. The electrolyte is conductive. When it comes in contact with the PC board, there is a possibility of pattern corrosion or short circuit between the circuit pattern, which could result in smoking or catching fire. Do not locate any circuit pattern beneath the capacitor end seal.

9) Do not design a circuit board that the heat generating components are placed near the aluminum electrolytic capacitor or on the reverse side of PC board, if that just under the capacitor.

10) Electrical characteristics may vary depending on changes in temperature and frequency. Please consider this variation when you design circuits.

11) When you install more than 2 capacitors in parallel, please consider the balance of current flowing into the capacitors.

12) While mounting capacitors on double-side PC board, the capacitors should be away from those unnecessary base plate holes and connection holes.

Mounting

1) Once a capacitor has been assembled in the set and power applied, do not attempt to re-use the capacitor in other circuits or application.

2) Leakage current of the capacitors that have been stored for more than 2 years may increase. When leakage current has increased, please perform a voltage treatment using a 1kΩ resistor.

3) Please confirm specifications and polarity before installing capacitors on the PC board.

4) Do not drop capacitors on the floor, nor use a capacitor that was dropped.

5) Do not deform the capacitor during installation.

6) Please pay attention to the mechanical shock to the capacitor by suction nozzle of the automatic insertion machine or automatic mounter, or by product checker, or by centering mechanism.

SMD ALUMINUM ELECTROLYTIC CAPACITORS UZ SERIES

Reflow soldering

- 1) Please follow “Reflow Soldering Conditions” when use the part.
 - 2) When an infrared heater is used, please pay attention to the extent of heating since the absorption rate of infrared will vary due to difference in the color and size of the capacitor.
 - (1) Do not tilt lay down or twist the capacitor body after the capacitor are soldered to the PC board.
 - (2) Do not carry the PC board by grasping the soldered capacitor.
 - (3) Please do not allow anything to touch the capacitor after soldering. If PC boards are stored in stack, please make sure the PC board or other components away from the capacitor.
 - (4) The capacitors shall not be effected by any radiated heat from the soldered PC board or other components after soldering.
 - (5) Cleaning:
 - (a) Do not clean capacitors with halogenated cleaning agent. However, if it is necessary to clean with halogenated cleaning agent, please contact our sales office.
 - (b) Recommended cleaning method, Applicable : Any type, any ratings
- Cleaning conditions: Total cleaning time shall be within 2 minutes by immersion, ultrasonic or other methods. Temperature of the cleaning agents shall be 40°C or below. After cleaning, capacitors should be dried by using hot air for the minimum 10 minutes along with the PC board mounted. Hot air temperature should be within the maximum operating temperature of the capacitor. Insufficient dryness after water rinse may cause appearance problems, such as bottom-plate bulge and etc.; Avoid using ozone destructive substances as cleaning agents for protecting global environment.

In the PCB after mounted

- 1) Do not directly touch terminal by hand.
- 2) Do not link positive terminal and negative terminal by conductor, nor spill conductible liquid such as alkaline or acidic solution on or near the capacitor.
- 3) Please make sure that the ambient conditions where the set is installed are free from spilling water or oil, direct sunlight, ultraviolet rays, radiation, poisonous gases, vibration or mechanical shock.

SMD ALUMINUM ELECTROLYTIC CAPACITORS UZ SERIES

Maintenance and Inspection

Please periodically inspect the aluminum capacitors that are installed in industrial equipment. The following items should be checked:

Appearance: remarkable abnormality such as pressure relief vent opening, electrolyte leaking, etc.

Electrical characteristics: capacitance, dielectric loss tangent, leakage current and etc., which are specified in catalogue or alternate product specification.

In an Emergency

- 1) If you see smoke due to operation of safety vent, please turn off the main switch or pull out the plug from the outlet.
- 2) If you breathe the gas or ingest the electrolyte, please wash out your mouth and throat with water immediately.
- 3) If your skin is exposed to the electrolyte, please wash it away using soap and water.

Storage

- 1) Do not keep capacitor in high temperature and high humidity atmosphere. Storage conditions should be:

Temperature: 5°C~35°C Humidity : lower than 75% Place : Indoor

- 2) Avoid ambient conditions where capacitors are covered with water, brine or oil.

Disposal

Please take either of the following methods in disposing capacitors.

- 1) Incinerate them after crushing capacitors or making a hole on the capacitor body.
- 2) If incineration is not applicable, hand them over to a waste disposal agent and have them buried in landfills.

DISCLAIMER

NextGen Component, Inc. reserves the right to make changes to the product(s) and or information contained herein without notice. No liability is assumed as a result of their use or application. No rights under any patent accompany the sale of any such product(s) or information